

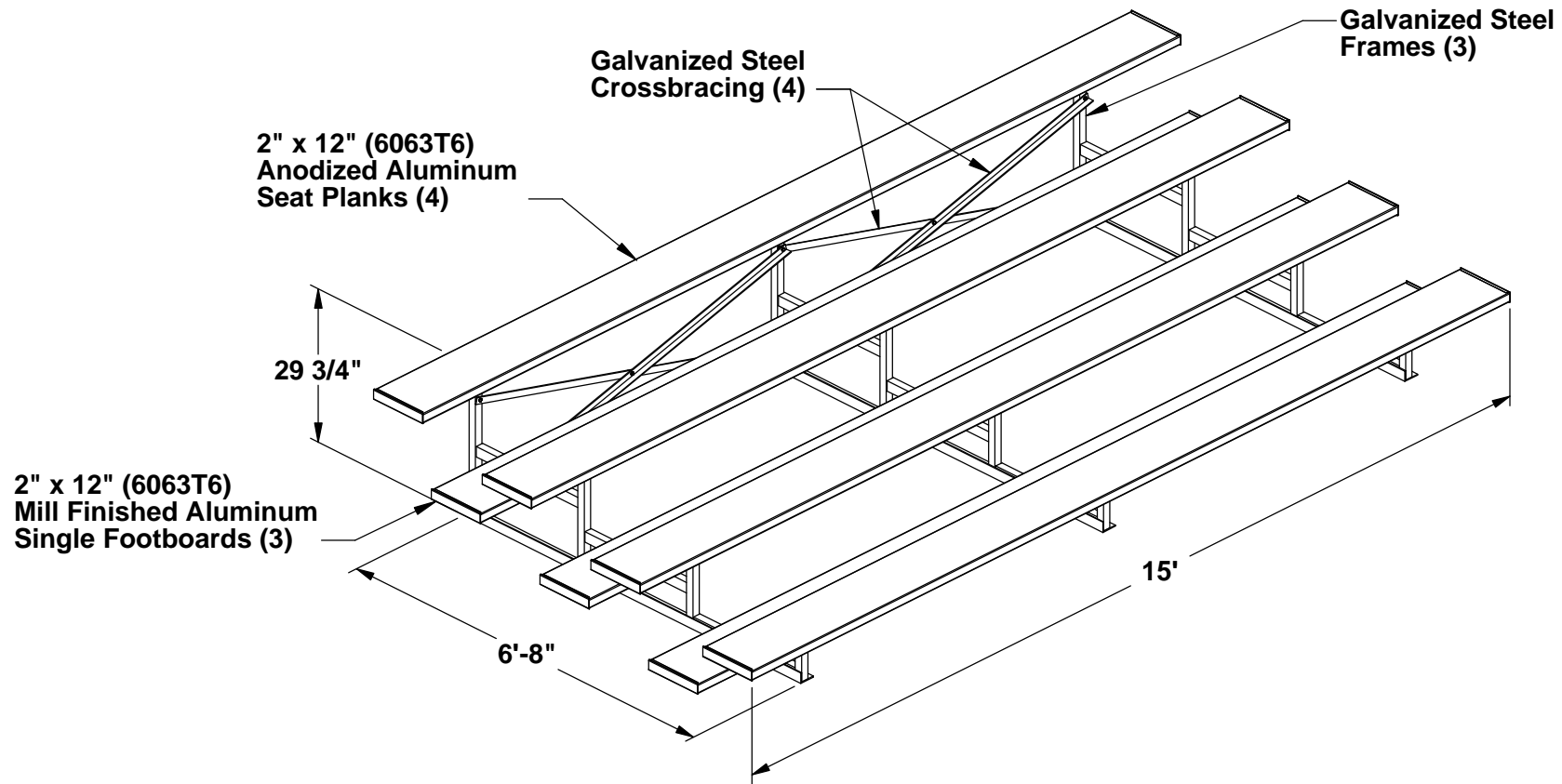

PB-415/ICC **General Specifications**



Overall Weight = 280 lbs.

 Aluminum Athletic Equipment 4 Portland Road, West Conshohocken, PA 19428 Phone: (610) 825-6565 Toll Free: (800) 523-5471		
DESCRIPTION		
PB-415/ICC General Specifications		
NOTE: 15' Long Planks / 4 Row		
MODEL:	CATEGORY:	DATE:
PB-415/ICC	CUSTOMER	6/12/02
DWN. BY:	CAD FILE:	DWG. NO.
TAD	PB-415/ICC General Specs	PB415-ICC-C-001

PB-415/ICC - Specifications

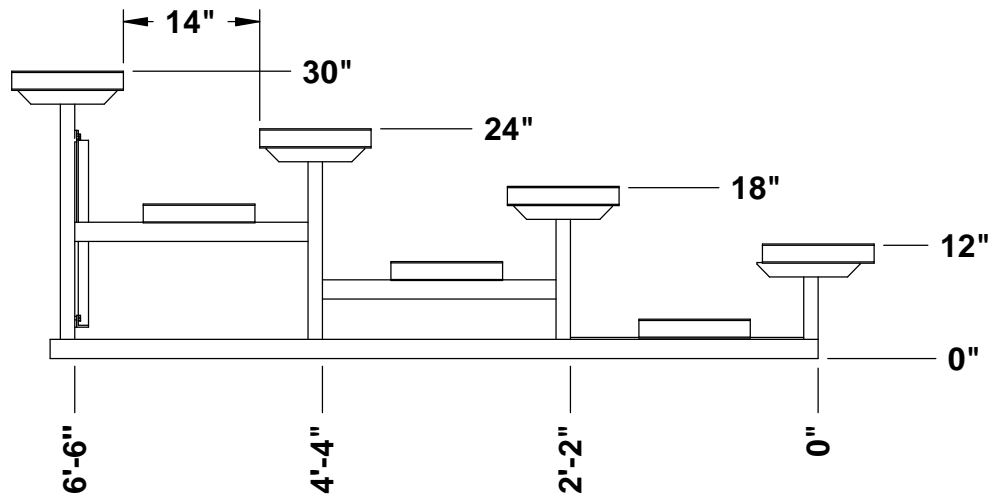
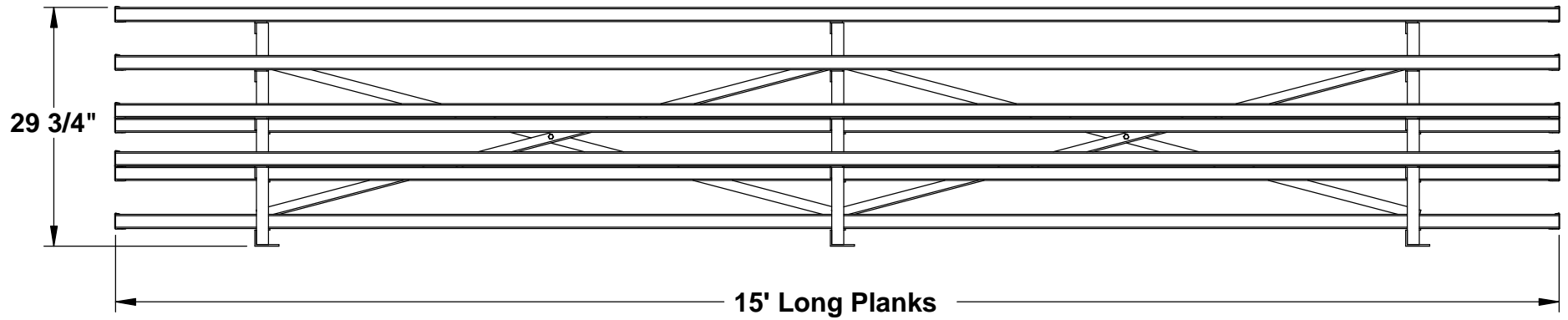

Material:

Galvanized Steel Frames
Aluminum Planking and Seat Clips
Stainless Steel Hardware



Aluminum Athletic Equipment
 4 Portland Road, West Conshohocken, PA 19428
 Phone: (610) 825-6565 Toll Free: (800) 523-5471



DESCRIPTION		
PB-415/ICC - Specifications		
NOTE: Single Footboards		
MODEL: PB-415/ICC	CATEGORY: CUSTOMER	DATE: 6/5/03
DWN. BY: TAD	CAD FILE: PB-415/ICC Specifications	DWG. NO. PB415-ICC-C-002

PB-415-ICC - Step No. 1

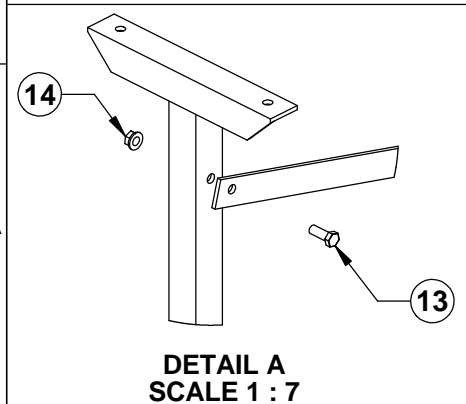
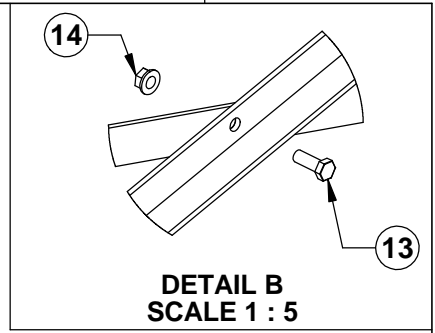
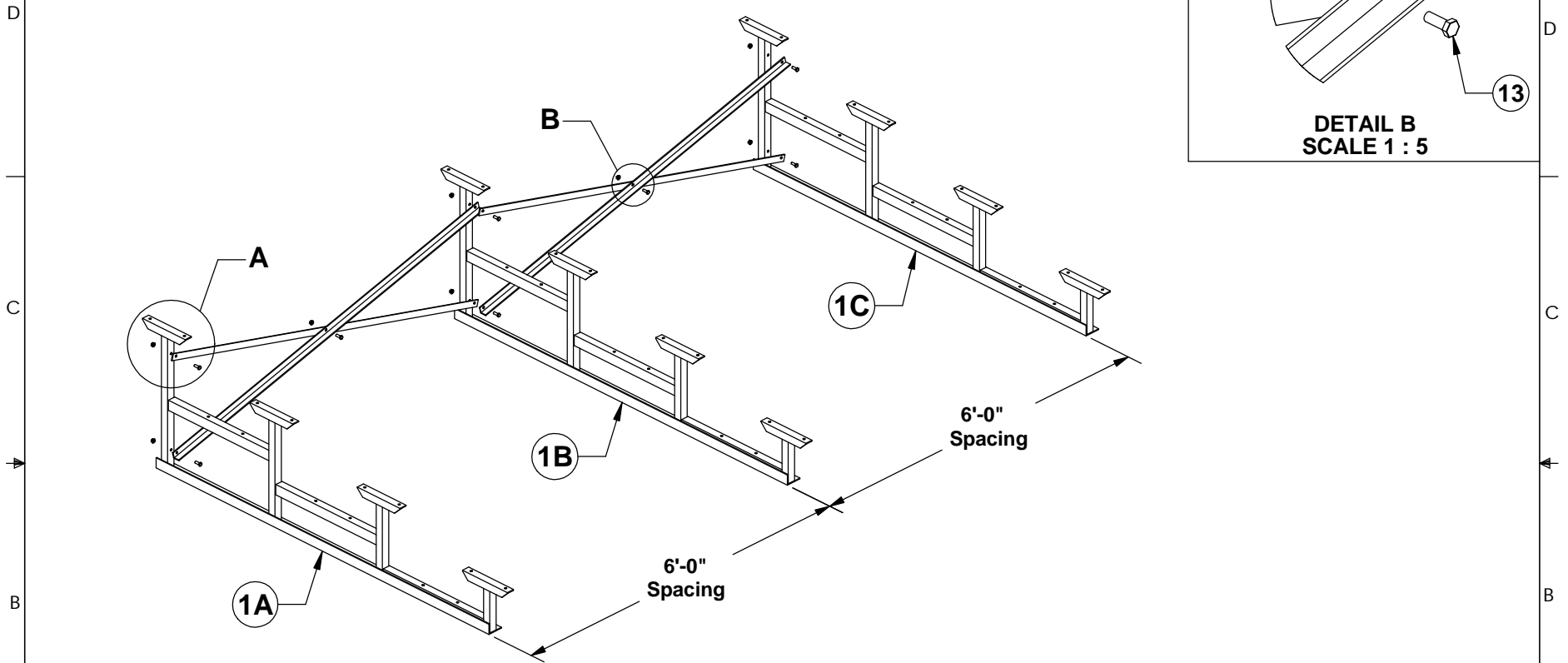
Steel Frames & Crossbracing Assembly



Hardware Used in this Step:

-  1) 3/8"-16 x 1" S.S. Bolts (Item No.13) = 8 total
-  2) 3/8"-16 S.S. Wiz-loc Nuts (Item No.14) = 8 total

**** Note: Make sure, when assembling, to ratchet bolt, not nut.**

AAE Aluminum Athletic Equipment 4 Portland Road, West Conshohocken, PA 19428 Phone: (610) 825-6565 Toll Free: (800) 523-5471		
DESCRIPTION	PB-415-ICC - Step No. 1	
NOTE:	Galvanized Steel Frame & Crossbracing Assembly	
MODEL:	PB-415-ICC	DATE: 10/16/02
	CATEGORY: CUSTOMER	
DRAWN BY:	CAD FILE:	DWG. NO.:
TAD	PB-415-ICC - Step No. 1	PB-415-ICC-C-003

8 7 6 5 4 3 2 1

PB-415-ICC Step No. 2
Attaching End Caps &
Planking Assembly

2 Holes

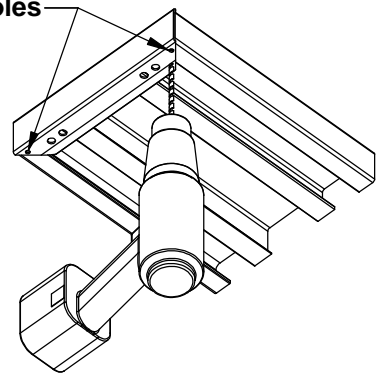

Drilling End Caps
 (for attachment to planks)

19

20

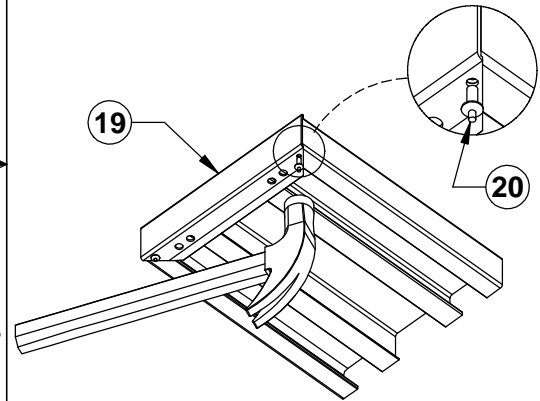

Riveting End Caps
 (for permanent attachment)

Tools Required:

- 1) 1/2 - Ratchet
- 2) 9/16 - Ratchet
- 3) Hand Drill with 3/16" drill bit
- 4) Hammer

****Note: When assembling crossbracing, make sure to tighten the bolt end, not the nut**

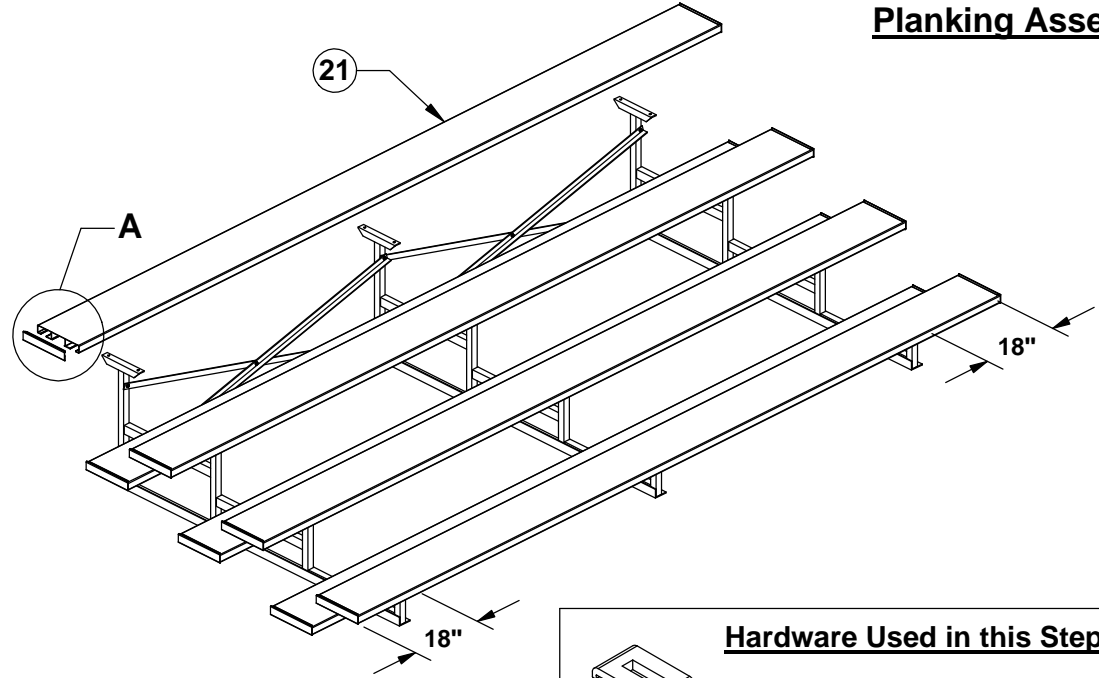

17



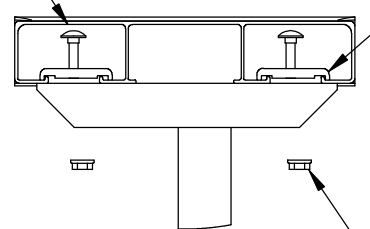

16

18

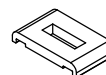

DETAIL A
Attaching Planks

Hardware Used in this Step:

-  1) Aluminum Seat Clip (Item No.16) = 42 total
-  2) 1/4"-20 x 1" S.S. Carriage Bolt (Item No.17) = 42 total
-  3) 1/4"-20 S.S. Wiz-loc Nuts (Item No.18) = 42 total
-  4) 3/16" Aluminum Rivet (Item No.20) = 28 total



Aluminum Athletic Equipment
 4 Portland Road, West Conshohocken, PA 19428
 Phone: (610) 825-6565 Toll Free: (800) 523-5471

DESCRIPTION			PB-415-ICC - Step No. 2		
NOTE: Drilling End Caps & Planking Assembly					
MODEL:	PB-415-ICC	CATEGORY:	CUSTOMER	DATE:	11/30/01
DRAWN BY:	TAD	CAD FILE:	PB-415-ICC - Step No. 2	DWG. NO.:	PB-415-ICC-C-004

6 5 4 3 2 1

**PB-415/ICC
(SINGLE FOOTBOARDS)
ASSEMBLY INSTRUCTIONS**

Step No. 1

Refer to Drawing: **Steel Frames & Crossbracing Assembly**

(*Make sure to ratchet the bolt, not the wiz-loc nut!)

1. Attach all crossbracing together at their center holes before attaching to bleacher frames using 3/8"-16 x 1" bolts and 3/8"-16 wiz-loc nuts (Item Nos.13 & 14).
(See "Detail B")
(ex: 2A to 2B for each side)
2. Evenly position bleacher frames (Item Nos.1A/1B/1C) approximately 6 feet apart.
3. Scissor crossbracing (Item Nos.2A/2B) and attach to bleacher frames using 3/8"-16 x 1" bolts and 3/8"-16 wiz-loc nuts (Item Nos. 13 & 14).
(See "Detail A")

Step No. 2

Refer to Drawing: **Attaching End Caps & Planking**

1. Place End Caps (Item No.19) on Planks (Item No.21) and make sure they are even with the sides of the planks.
2. Using a hand drill with a 3/16" drill bit, drill through the planks where the pre-drilled holes are on the 2 outer holes on the end caps.
(See "Drilling End Caps" Detail)
3. Align 3/16" aluminum rivets (Item No.20) with newly drilled holes & hit the rivet head using any type of hammer.
(See "Riveting End Caps" Detail)
4. Attach seat and foot planks to bleacher frame accordingly **(See "Detail A")**. Each plank should overhang bleacher frame by 18" on each side. Each plank attaches to the frames at 6 locations. Tighten and check all connections.

FOR TECHNICAL ASSISTANCE, CALL 1-800-523-5471